

SNA-6 Series
FC ADAPTOR
- Oval flange for Angled-PC -
TECHNICAL SPECIFICATIONS



SEIKOH GIKEN Co.,Ltd.
Fiber Optic Products Division
296-1, MATSUHIDAI, MATSUDO-SHI,
CHIBA, 270-2214 JAPAN.
TEL: +81-47-388-6111 FAX: +81-47-388-4477

SNA-6 Series FC ADAPTOR – Oval flange for Angled - PC –
TECHNICAL SPECIFICATIONS

S04-011-0	June	1995
S04-011-1	June	1997
S04-H027-01E	October	2006

Copyright © 1995 - 2006 by **SEIKOH GIKEN Co.,Ltd.**
All right reserved.

The information contained herein shall not be reproduced or disclosed to any third party without the express written consent of SEIKOH GIKEN Co., Ltd.
The specifications contained herein are subject to change without notice.

Please address any questions, comments and suggestions to:

SEIKOH GIKEN USA, Inc.

Headquarters

4405 International Blvd., Suite B109
Norcross, GA 30093 U.S.A.
TEL: +1-770-279-6602 FAX: +1-770-279-8839

Northeastern Field Office

714 Executive Drive
Princeton, NJ 08540
TEL: +1-609-279-0225 FAX: +1-609-279-0207

Western Field Office

21250 Hawthorne Boulevard, Suite 700
Torrance, CA 90503
TEL: +1-310-792-7450 FAX: +1-310-792-7451

SEIKOH GIKEN Europe GmbH

Frankfurt Branch

Siemensstrasse 9
D-63263 Neu-Isenburg, Germany
TEL: +49-6102-297-701
FAX: +49-6102-297-750

SEIKOH GIKEN Hong Kong Co.,Ltd.

Concordia Plaza 21/F Rm2111,
1 Science Museum Road, Tsim Sha Tsui East,
Kowloon, Hong Kong.
TEL: +852-26206551 FAX: +852-26206525

TABLE OF CONTENTS

Section		Page
1	SCOPE	1
2	PART NUMBER	1
3	GENERAL SPECIFICATIONS	2
3.1	Physical Dimensions	2
3.2	Insertion Loss	2
3.3	Appearance	2
4	FEATURE	2
4.1	Mechanical Characteristics	2
4.2	Environmental Characteristics	2
5	PACKING	3
6	IDENTIFICATION	3
7	HANDLING AND CARE	3
7.1	Conditions of Storage	3
7.2	Precautions of Use	3
7.3	Disposal	3
8	DRAWING	3

Table

Table 1	Part Number	1
Table 2	Mechanical Characteristics	2
Table 3	Environmental Characteristics	2

1 SCOPE

These specifications apply to the SNA-6 series FC adaptor – Oval flange for Angled - PC - supplied by SEIKOH GIKEN Co., Ltd.

2 PART NUMBER

Part number of the housing is shown in Table 1.

Table 1 Part Number

MODEL Number	TYPE Number					
SNA-6	2	1	B	K	0	G
	Slit Sleeve				Auxiliary digit	
	2	Zirconia			0 G	
	Marking				Specification	
	1	No Marking			K	R-Type -Narrow Key -
	Cap					
	B	Green Plastic Cap				

Please contact us for other specifications.

3 GENERAL SPECIFICATIONS

3.1 Physical Dimensions

The product shall meet the specification in drawings.

- In accordance with IEC 61754-13 Type FC-PC connector family.
- In accordance with JIS C 5970 F01 Type connectors.

3.2 Insertion Loss

Insertion loss shall be less than 0.2dB by the measurement method L04-008n-2

3.3 Appearance

There should be no burr, peeling of plating or scratches that affect the product.

4 FEATURE

4.1 Mechanical Characteristics

Mechanical characteristics are shown in table 2.

Table 2 Mechanical characteristics

Test item	Conditions		Characteristics
Vibration	JIS C 5961 7.1	Frequency :10~50Hz Amplitude :0.75mm Duration :30 minutes / direction	Insertion loss <=0.5dB
Durability	JIS C 5961 7.3	Times of matching : >=500 times	
Maintaining force of the sleeve gauge	JIS C 5961 7.4	Gauge : 2.499+/-0.0005mm	2.9 ~ 5.9N (0.3 ~ 0.6kgf)
Intensity of the joint (along the ferrule axis)	JIS C 5961 7.6	Intensity for pulling :147N(15kg) Fiber length under test :1 to 2m	Insertion loss <=0.5dB

4.2 Environmental Characteristics

Environmental characteristics are shown in table 3.

Table 3 Environmental characteristics

Test item	Conditions		Characteristics
Heat cycle	JIS C 5961 8.2	-40 ~ +85 degreeC, 10cycle	Insertion loss <=0.5dB
High humidity resistance (Constant temp)	JIS C 5961 8.4	40 degreeC,95%RH ,10cycle	
Heat resistance	JIS C 5961 8.5	85 degreeC,240hours	
Cold resistance	JIS C 5961 8.6	-40 degreeC,240hours	

5 PACKING

The product is packed to prevent damage during shipment.

6 IDENTIFICATION

Identification label should indicate the part number and lot number of the product(s) and should be permanently attached to the packing bag.

7 HANDLING AND CARE

7.1 Conditions of Storage

Keep the product, in the packing bag, at the following conditions for its storage.

- Storage temperature: -40 to +85 degrees C
- Storage humidity: 0 to 85%RH, non-condensing

7.2 Precautions for Use

Contamination, oil, sweat and others debris on the inside of the slit sleeve may influence the performance of the product. If contamination is on the inside of the slit sleeve, clean the inside before connecting.

7.3 Disposal

When discarding this product, please follow the regulations of your own country.

8 DRAWING

- S04-H027-D01E : SNA-621BK0G
- Insertion loss measurement method. : L04-008n-2

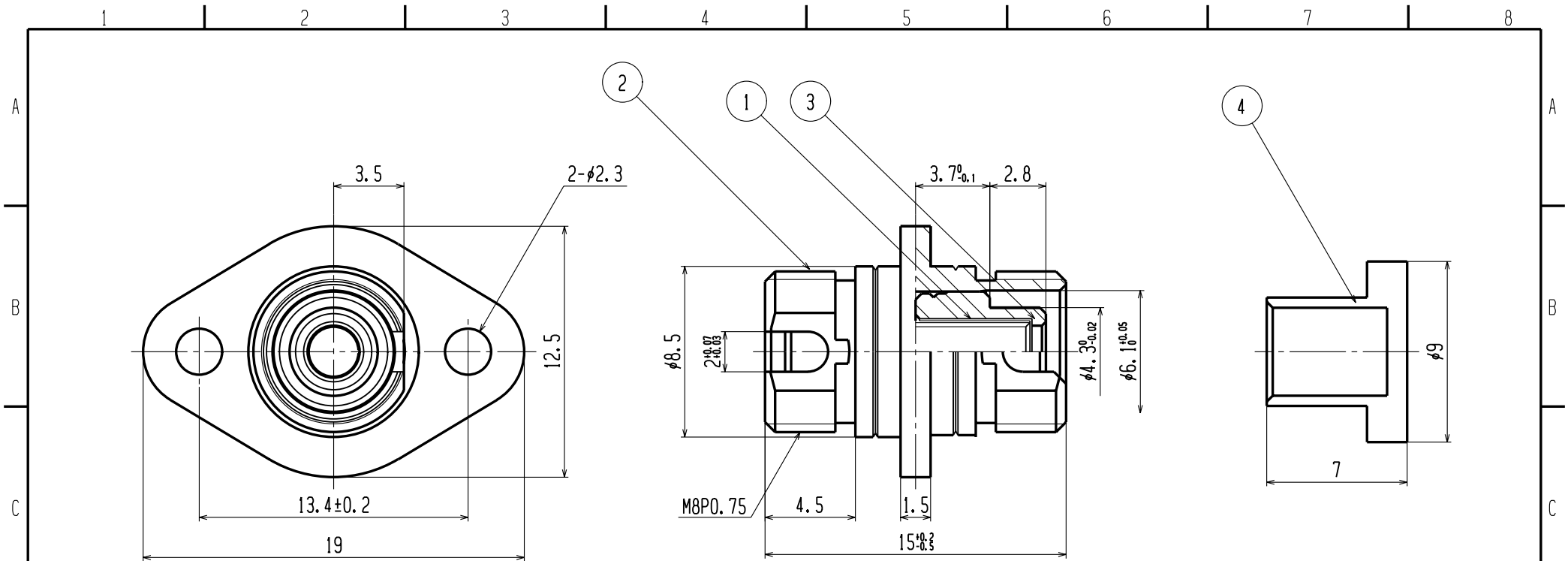

4	2	PROTECTION CAP (GREEN)	PP	
3	1	SLEEVE HOLDER	BRASS	Ni PLATING
2	1	HOUSING	BRASS	Ni PLATING
1	1	SLEEVE	ZIRCONIA	NOT INCLUDING
NO (番号)	QTY (数量)	TITLE (名称)	MATERIAL (材料)	TREATMENT (処理)

PARTS LIST
(部品表)

MATERIAL (材料)		PART NO. (型番)		SNA-6 Series	
TREATMENT (処理)		TITLE (名称)		SNA-621BK0G	
SCALE (尺度)	UNIT (単位)	DATE (日付)	FC ADAPTOR		
Free	1=1mm	2006/10/20	(Oval flange for Angled-PC)		
APPROVED BY (承認)	CHECKED BY (検閲)	DESIGNED BY (設計)	DRAWN BY (製図)	ITEM NO. (品目コード)	SHEET NO. (枚数)
Y. KAKUTANI	K. KURUMADAM.	JIBIKI	M. JIBIKI		
SEIKOH GIKEN Co., Ltd.			DRAWING NO. (図番)	S04-H027-D01E	PAGE (ページ)

△		
△		
△		
ISSUED	2006/10/20	
REP. V. (図版)	DESIGN CHANGE (設計変更)	DATE (日付)

INSERTION LOSS MEASUREMENT METHOD OF ADAPTORS

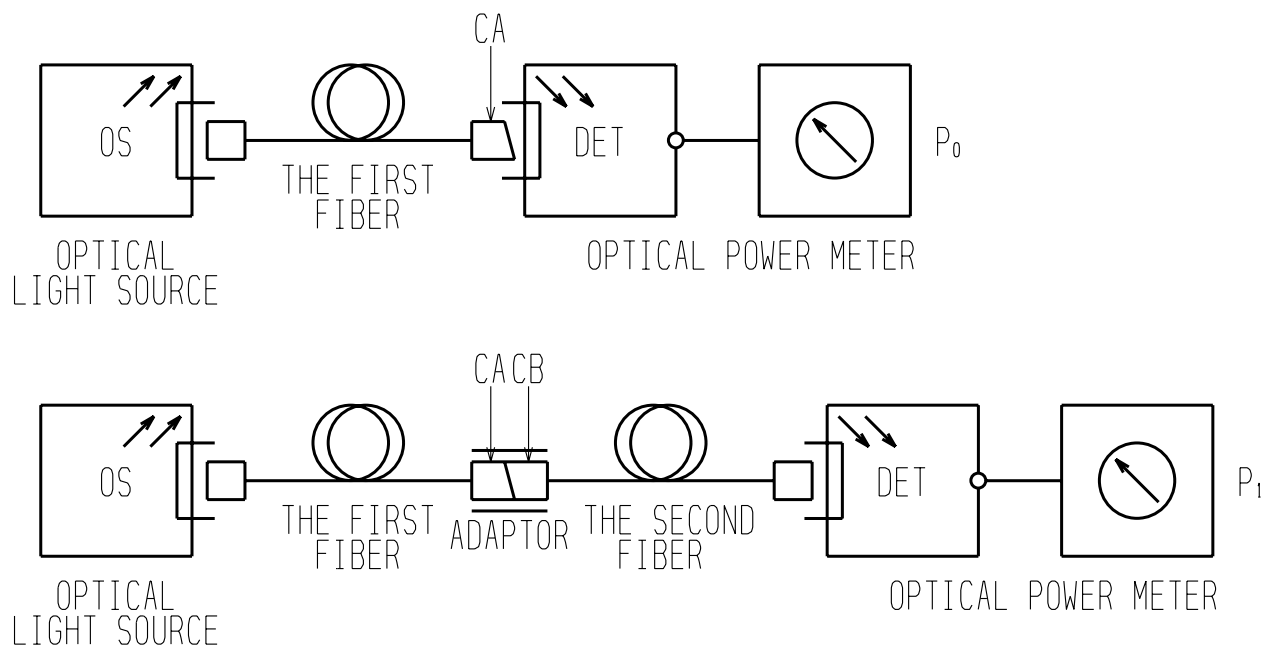

DESCRIPTION

CA and CB: Master connectors (satisfied the following specifications)

•Fiber length : $\geq 2\text{m}$

•Diameter of the ferrule : $\phi 2.499 \pm 0.0005\text{mm}$ (FC, SC),

$\phi 1.249 \pm 0.0005\text{mm}$ (MU), $\phi 1.249 \pm 0.0007\text{mm}$ (LC)

•Fiber core eccentricity : $\leq 0.5\mu\text{m}$ (FC, SC, MU, LC)

(For reference only since the value is measured before APC polishing.)

•Vertex offset : $\leq 30\mu\text{m}$

•Radius of curvature : 5~12mm

•Protrusion of the fiber from the ferrule end face : $-0.05 \sim 0.05\mu\text{m}$

•Insertion loss : $\leq 0.1\text{dB}$

•Return loss : $\geq 60\text{dB}$

Optical light source: $1300 \pm 30\text{nm}$ LD light source

Insertion loss = $-10 \log_{10}(P_1/P_0)$