

# **SGP-3 Series**

## **FC HOUSING**

### **for PC**

- 360 degree variable tuning -

## **TECHNICAL SPECIFICATIONS**



**SEIKOH GIKEN Co.,Ltd.**  
**Fiber Optic Products Division**  
296-1, MATSUHIDAI, MATSUDO-SHI,  
CHIBA, 270-2214 JAPAN.  
TEL: +81-47-388-6111 FAX: +81-47-388-4477

SGP-3 Series FC HOUSING for PC – 360 degree variable tuning –  
TECHNICAL SPECIFICATIONS

S05-001-0	August	1995
S05-001-1	June	2006
S05-H032-01E	October	2006
S05-H032-02E	September	2007

Copyright © 1995 - 2007 by **SEIKOH GIKEN Co.,Ltd.**  
All right reserved.

The information contained herein shall not be reproduced or disclosed to any third party without the express written consent of SEIKOH GIKEN Co., Ltd.  
The specifications contained herein are subject to change without notice.

Please address any questions, comments and suggestions to:

**SEIKOH GIKEN USA, Inc.**  
**Headquarters**

4405 International Blvd., Suite B109  
Norcross, GA 30093 U.S.A.  
TEL: +1-770-279-6602 FAX: +1-770-279-8839

**Northeastern Field Office**

714 Executive Drive  
Princeton, NJ 08540  
TEL: +1-609-279-0225 FAX: +1-609-279-0207

**Western Field Office**

21250 Hawthorne Boulevard, Suite 700  
Torrance, CA 90503  
TEL: +1-310-792-7450 FAX: +1-310-792-7451

**SEIKOH GIKEN Europe GmbH**  
**Frankfurt Branch**

Siemensstrasse 9  
D-63263 Neu-Isenburg, Germany  
TEL: +49-6102-297-701  
FAX: +49-6102-297-750

**SEIKOH GIKEN Hong Kong Co.,Ltd.**

Concordia Plaza 21/F Rm2111,  
1 Science Museum Road, Tsim Sha Tsui East,  
Kowloon, Hong Kong.  
TEL: +852-26206551 FAX: +852-26206525

## TABLE OF CONTENTS

Section	Page
1 SCOPE	1
2 PART NUMBER	1
3 GENERAL SPECIFICATIONS	2
3.1 Physical Dimensions	2
3.2 Appearance	2
4 FEATURE	2
4.1 Mechanical Characteristics	2
4.2 Environmental Characteristics	2
5 PACKING	3
6 IDENTIFICATION	3
7 HANDLING AND CARE	3
7.1 Conditions of Storage	3
7.2 Precautions of Use	3
7.3 Disposal	3
8 DRAWING	3

### Table

Table 1	Part Number	1
Table 2	Mechanical Characteristics	2
Table 3	Environmental Characteristics	2



1 SCOPE

These specifications apply to the SGP-3 series FC housing for PC – 360 degree variable tuning – supplied by SEIKOH GIKEN Co., Ltd.

2 PART NUMBER

Part number of the housing is shown in Table 1.

Table 1 Part Number

MODEL Number		TYPE Number																																							
<b>SGP-3</b>		<b>5</b>	<b>6</b>	<b>0</b>	<b>0</b>	<b>1</b>	<b>K</b>	<b>0</b>	<b>G</b>																																
<table border="1"> <tr><td colspan="2">Boot Color</td></tr> <tr><td>5</td><td>Blue</td></tr> </table>		Boot Color		5	Blue	<table border="1"> <tr><td colspan="2">Boot I.D. [mm] , Marking</td></tr> <tr><td>6 0</td><td>for ø 2 cord (Flexible) No Marking</td></tr> <tr><td>7 0</td><td>for ø 3 cord (Flexible) No Marking</td></tr> </table>		Boot I.D. [mm] , Marking		6 0	for ø 2 cord (Flexible) No Marking	7 0	for ø 3 cord (Flexible) No Marking	<table border="1"> <tr><td colspan="2">Specification</td></tr> <tr><td>K</td><td>Mold frame</td></tr> <tr><td>J</td><td>Cutout frame</td></tr> </table>		Specification		K	Mold frame	J	Cutout frame	<table border="1"> <tr><td colspan="2">Auxiliary digit</td></tr> <tr><td colspan="2">0 G</td></tr> </table>		Auxiliary digit		0 G		<table border="1"> <tr><td colspan="2">Package</td></tr> <tr><td>1</td><td>Main body tentatively assembled, Bulk Package</td></tr> </table>		Package		1	Main body tentatively assembled, Bulk Package	<table border="1"> <tr><td colspan="2">Cap</td></tr> <tr><td>0</td><td>No Cap</td></tr> <tr><td>1</td><td>Black Cap</td></tr> </table>		Cap		0	No Cap	1	Black Cap
Boot Color																																									
5	Blue																																								
Boot I.D. [mm] , Marking																																									
6 0	for ø 2 cord (Flexible) No Marking																																								
7 0	for ø 3 cord (Flexible) No Marking																																								
Specification																																									
K	Mold frame																																								
J	Cutout frame																																								
Auxiliary digit																																									
0 G																																									
Package																																									
1	Main body tentatively assembled, Bulk Package																																								
Cap																																									
0	No Cap																																								
1	Black Cap																																								

Please contact us for other specifications.

### 3 GENERAL SPECIFICATIONS

#### 3.1 Physical Dimensions

The product shall meet the specification in drawings.

- In accordance with IEC 61754-13 Type FC-PC connector family.
- In accordance with JIS C 5970 F01 Type connectors.

#### 3.2 Appearance

There should be no burr, peeling of plating or scratches that affect the product.

### 4 FEATURE

#### 4.1 Mechanical Characteristics

Mechanical characteristics are shown in table 2.

Table 2 Mechanical characteristics

Test item	Conditions		Appearance & function
Vibration	IEC 61300-2-1	Frequency: 10 to 55 Hz Amplitude: 1.5 mm p-p Direction: x, y, z axis Duration: 30 min / direction	There should be no deformation, crack, loose and other damages on the plug housing.
Tensile strength of coupling mechanism	IEC 61300-2-6	Tensile load: 147N(15kgf)	
Mating durability	IEC 61300-2-2	500 times	It can be joined without any mechanical abnormality.

#### 4.2 Environmental Characteristics

Environmental characteristics are shown in table 3.

Table 3 Environmental characteristics

Test item	Conditions		Appearance & function
Change of temperature	IEC 61300-2-22	-40 to +85 °C, 10 cycles	There should be no deformation, crack, loose and other damages on the plug housing.
Dry heat	IEC 61300-2-18	+85 °C, 240 hr	
Cold	IEC 61300-2-17	-40 °C, 240 hr	
Humidity / condensation cycling	Telcordia GR-326-CORE	-10 to +65 °C, 90 to 100 %RH, 14 cycles	

## 5 PACKING

The product is packed to prevent damage during shipment.

## 6 IDENTIFICATION

Identification label should indicate the part number and lot number of the product(s) and should be permanently attached to the packing bag.

## 7 HANDLING AND CARE

### 7.1 Conditions of Storage

Keep the product, in the packing bag, at the following conditions for its storage.

- Storage temperature: -40 to +85 degrees C
- Storage humidity: 0 to 85%RH, non-condensing

### 7.2 Precautions for Use

Contamination, oil, sweat and others debris on the ferrule end face may influence the performance of the product. If contamination is on the ferrule end face, wipe the end face with the end face cleaner.

### 7.3 Disposal

When discarding this product, please follow the regulations of your own country.

## 8 DRAWING

- S05-H032-D01E : SGP-356001K0G
- S05-H032-D02E : SGP-356001J0G
- S05-H032-D03E : SGP-357001K0G
- S05-H032-D04E : SGP-357001J0G
- S05-H032-D05E : SGP-356011K0G
- S05-H032-D06E : SGP-356011J0G
- S05-H032-D07E : SGP-357011K0G
- S05-H032-D08E : SGP-357011J0G

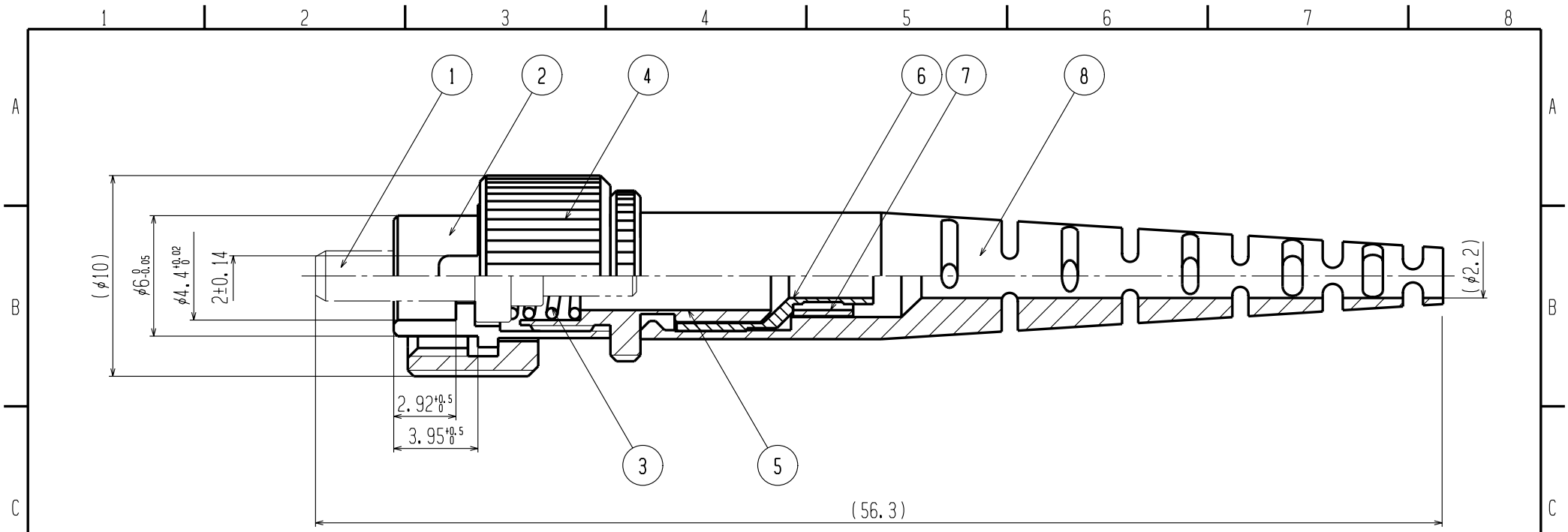

8	1	FLEXIBLE BOOT(BLUE)	PBT+Si	
7	1	RING	BRASS	Ni PLATING
6	1	CRIMP RING	ALUMINUM	
5	1	HOLDER	BRASS	Ni PLATING
4	1	COUPLING NUT	BRASS	Ni PLATING
3	1	COMPRESSION SPRING	STAINLESS STEEL WIRE	
2	1	FRAME	Zn DIECAST	Ni PLATING
1	(1)	FERRULE	-	NOT INCLUDING
NO (番号)	QTY (数量)	TITLE (名称)	MATERIAL (材料)	TREATMENT (処理)

PARTS LIST  
(部品表)

MATERIAL (材料)	PART NO. (型番)	SGP-3 Series
TREATMENT (処理)	SGP-356001K0G	
SCALE (尺度)	UNIT (単位)	DATE (日付)
Free	1=1mm	2007/06/15
APPROVED BY (承認)	CHECKED BY (検閲)	DESIGNED BY (設計)
Y. KAKUTANI	K. KURUMADA	M. JIBIKI
DRAWN BY (製図)		M. JIBIKI
ITEM NO. (品目コード)		SHEET NO. (枚数)
DRAWING NO. (図番)		PAGE (ページ)
SEIKOH GIKEN Co.,Ltd.		S05-H032-D01E

△		
△		
△	P/N CHANGE	2007/06/15
△	ISSUED	2006/10/20
Rev. (図歴)	DESIGN CHANGE (設計変更)	DATE (日付)

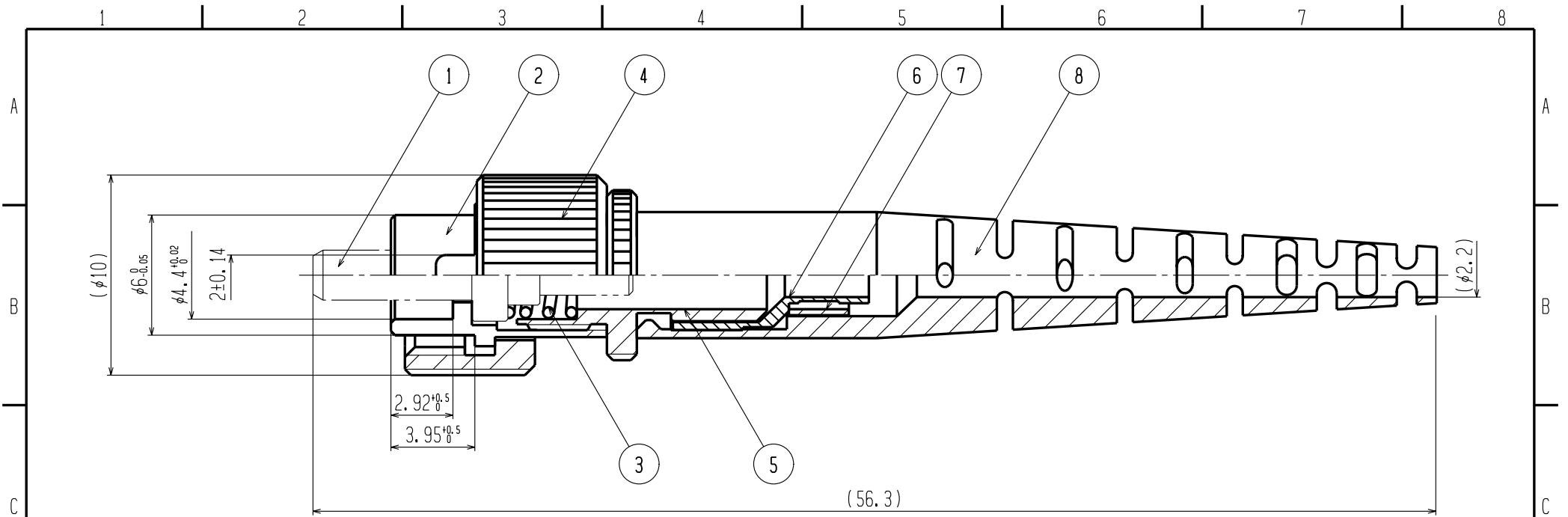

8	1	FLEXIBLE BOOT(BLUE)	PBT+Si	
7	1	RING	BRASS	Ni PLATING
6	1	CRIMP RING	ALUMINUM	
5	1	HOLDER	BRASS	Ni PLATING
4	1	COUPLING NUT	BRASS	Ni PLATING
3	1	COMPRESSION SPRING	STAINLESS STEEL WIRE	
2	1	FRAME	BRASS	Ni PLATING
1	(1)	FERRULE	-	NOT INCLUDING
NO (番号)	QTY (数量)	TITLE (名称)	MATERIAL (材料)	TREATMENT (処理)

PARTS LIST  
(部品表)

MATERIAL (材料)		PART NO. (型番)		SGP-3 Series	
TREATMENT (処理)		DATE (日付)		SGP-356001J0G	
SCALE (尺度)	UNIT (単位)	DATE (日付)		TITLE (名称)	
Free	1=1mm	2007/06/15		FC HOUSING for PC (360 degree variable tuning)	
APPROVED BY (承認)	CHECKED BY (検閲)	DESIGNED BY (設計)	DRAWN BY (製図)	ITEM NO. (品目コード)	SHEET NO. (枚数)
Y. KAKUTANI	K. KURUMADA	M. JIBIKI	M. JIBIKI		
SEIKOH GIKEN Co.,Ltd.				DRAWING NO. (図番)	PAGE (ページ)
				S05-H032-D02E	

△		
△		
△	P/N CHANGE	2007/06/15
△	ISSUED	2006/10/20
Rev. (図歴)	DESIGN CHANGE (設計変更)	DATE (日付)

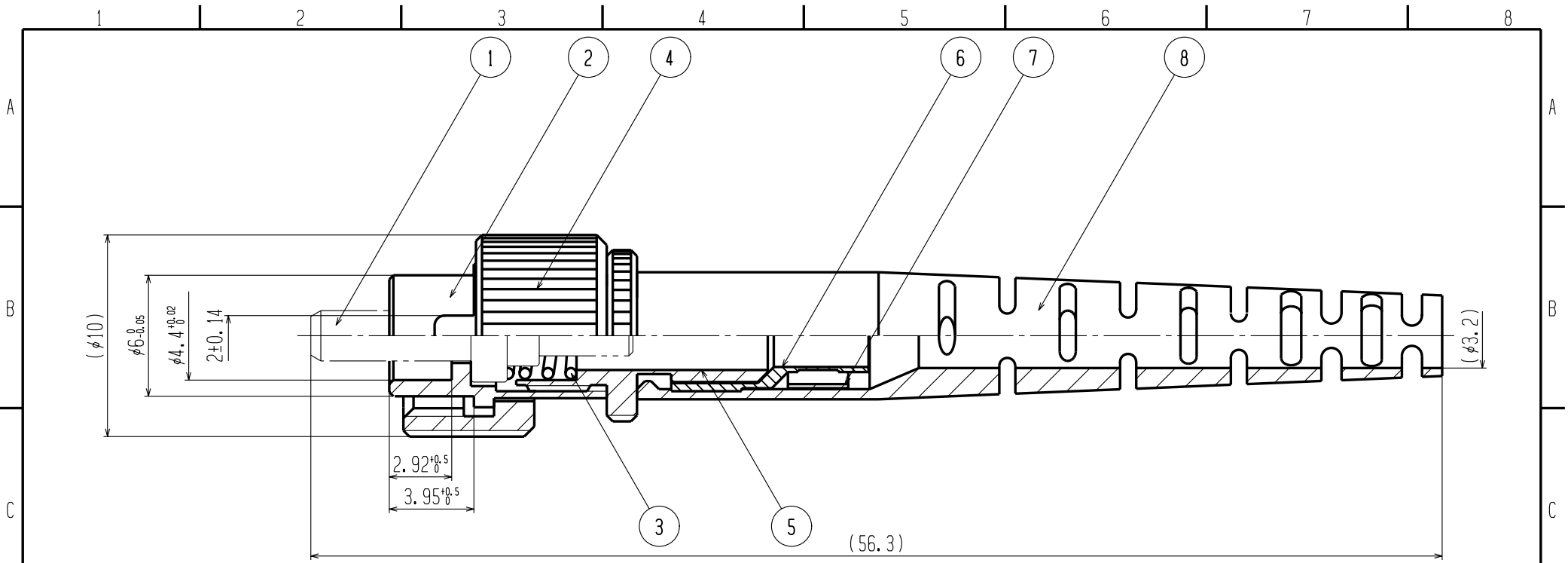

8	1	FLEXIBLE BOOT(BLUE)	PBT+Si	
7	1	RING	BRASS	Ni PLATING
6	1	CRIMP RING	ALUMINUM	
5	1	HOLDER	BRASS	Ni PLATING
4	1	COUPLING NUT	BRASS	Ni PLATING
3	1	COMPRESSION SPRING	STAINLESS STEEL WIRE	
2	1	FRAME	Zn DIECAST	Ni PLATING
1	(1)	FERRULE	-	NOT INCLUDING
NO (番号)	QTY (数量)	TITLE (名称)	MATERIAL (材料)	TREATMENT (処理)

PARTS LIST (部品表)

MATERIAL (材料)		PART NO. (型番)		SGP-3 Series	
TREATMENT (処理)		DATE (日付)		SGP-357001K0G	
SCALE (尺度)	UNIT (単位)	DATE (日付)		TITLE (名称)	
Free	1=1mm	2007/06/15		FC HOUSING for PC	
APPROVED BY (承認)	CHECKED BY (検閲)	DESIGNED BY (設計)	DRAWN BY (製図)	ITEM NO. (品目コード)	
Y. KAKUTANI	K. KURUMADA	M. JIBIKI	M. JIBIKI	SHEET NO. (枚数)	
SEIKOH GIKEN Co.,Ltd.				DRAWING NO. (図番)	
				S05-H032-D03E	
				PAGE (ページ)	

△		
△		
△	P/N CHANGE	2007/06/15
△	ISSUED	2006/10/20
Rev. (図歴)	DESIGN CHANGE (変更記事)	DATE (日付)

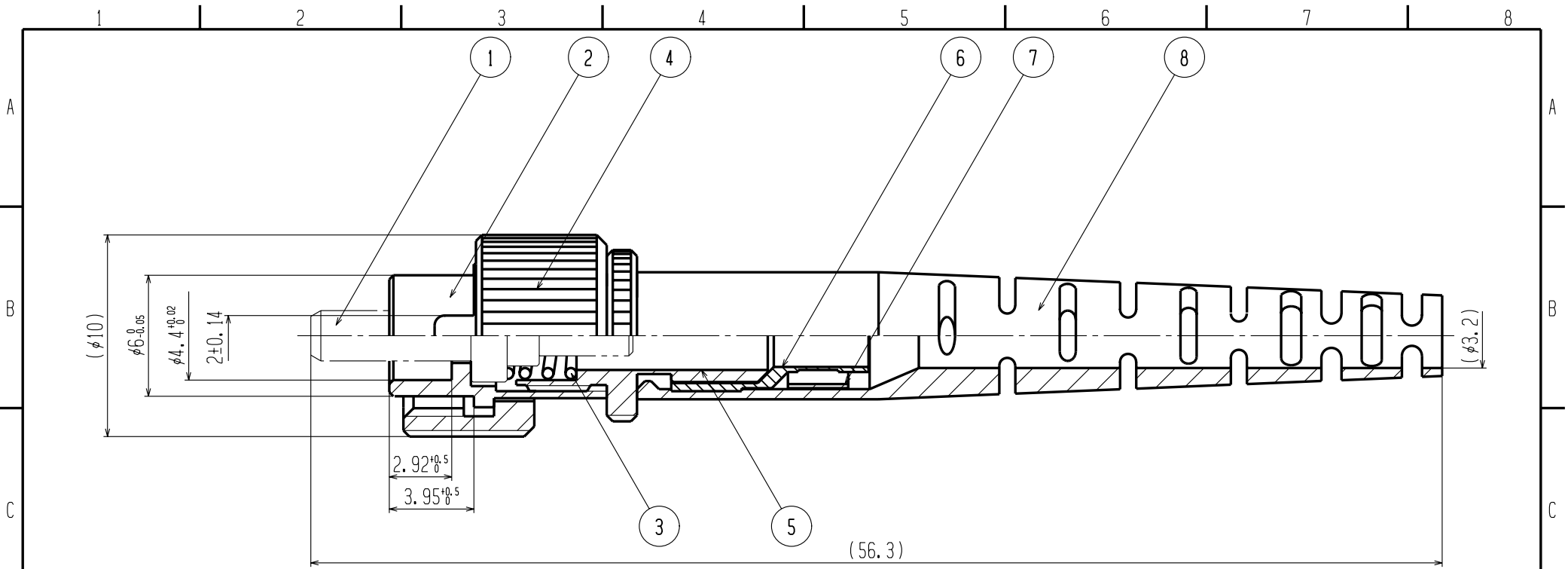

8	1	FLEXIBLE BOOT(BLUE)	PBT+Si	
7	1	RING	BRASS	Ni PLATING
6	1	CRIMP RING	ALUMINUM	
5	1	HOLDER	BRASS	Ni PLATING
4	1	COUPLING NUT	BRASS	Ni PLATING
3	1	COMPRESSION SPRING	STAINLESS STEEL WIRE	
2	1	FRAME	BRASS	Ni PLATING
1	(1)	FERRULE	-	NOT INCLUDING
NO (番号)	QTY (数量)	TITLE (名称)	MATERIAL (材料)	TREATMENT (処理)

PARTS LIST  
(部品表)

MATERIAL (材料)	PART NO. (型番)	SGP-3 Series	
TREATMENT (処理)	SGP-357001J0G		
SCALE (尺度)	UNIT (単位)	DATE (日付)	TITLE (名称)
Free	1=1mm	2007/06/15	FC HOUSING for PC (360 degree variable tuning)
APPROVED BY (承認)	CHECKED BY (検閲)	DESIGNED BY (設計)	DRAWN BY (製図)
Y. KAKUTANI	K. KURUMADA	M. JIBIKI	M. JIBIKI
SEIKOH GIKEN Co.,Ltd.			ITEM NO. (品目コード)
			SHEET NO. (枚数)
			PAGE (ページ)
			DRAWING NO. (図番)
			S05-H032-D04E

△		
△		
△	P/N CHANGE	2007/06/15
△	ISSUED	2006/10/20
Rev. (図歴)	DESIGN CHANGE (設計変更)	DATE (日付)

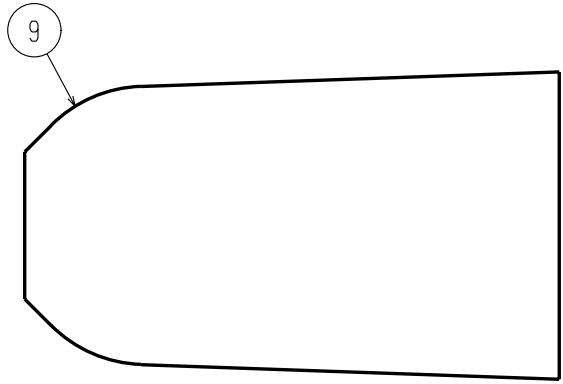
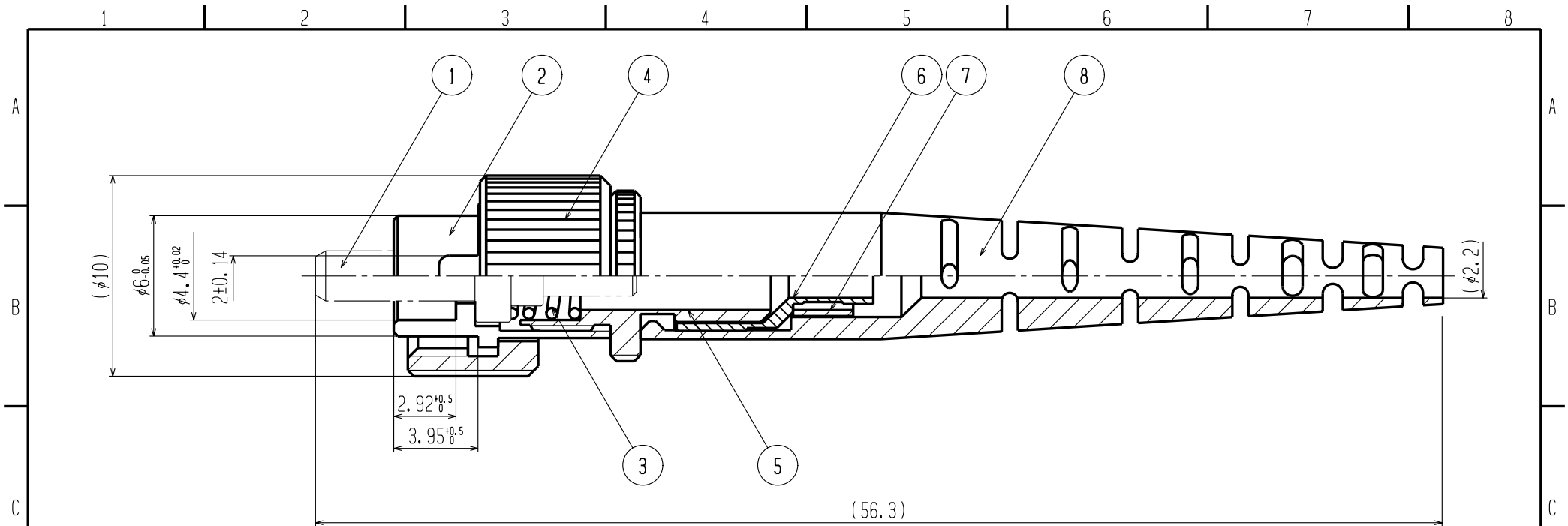

9	1	CAP(BLACK)	PVC	
8	1	FLEXIBLE BOOT(BLUE)	PBT+Si	
7	1	RING	BRASS	Ni PLATING
6	1	CRIMP RING	ALUMINUM	
5	1	HOLDER	BRASS	Ni PLATING
4	1	COUPLING NUT	BRASS	Ni PLATING
3	1	COMPRESSION SPRING	STAINLESS STEEL WIRE	
2	1	FRAME	Zn DIECAST	Ni PLATING
1	(1)	FERRULE	-	NOT INCLUDING
NO (番号)	QTY (数量)	TITLE (名称)	MATERIAL (材料)	TREATMENT (処理)

PARTS LIST  
(部品表)

MATERIAL (材料)		PART NO. (型番)		SGP-3 Series	
TREATMENT (処理)		SCALE (尺度)		TITLE (名称)	
Free		UNIT (単位)		SGP-356011K0G	
1=1mm		DATE (日付)		FC HOUSING for PC	
2007/09/03		APPROVED BY (承認)		(360 degree variable tuning)	
Y. KAKUTANI		CHECKED BY (検閲)		ITEM NO. (品目コード)	
D. KUBO		DESIGNED BY (設計)		SHEET NO. (枚数)	
M. JIBIKI		DRAWN BY (製図)		PAGE (ページ)	
M. JIBIKI		DRAWING NO. (図番)		S05-H032-D05E	
<b>SEIKOH GIKEN Co.,Ltd.</b>					

△		
△		
△		
1	ISSUED	2007/09/03
Rev. (回 数)	DESIGN CHANGE (設計変更)	DATE (日付)

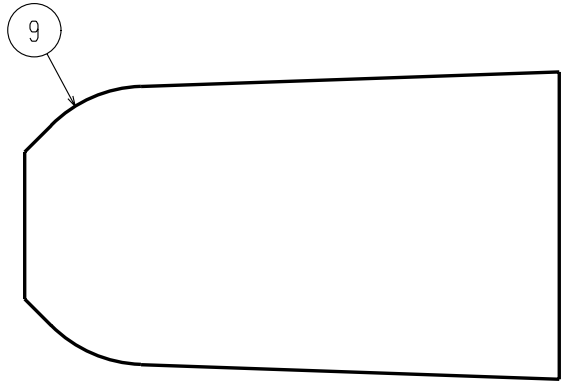
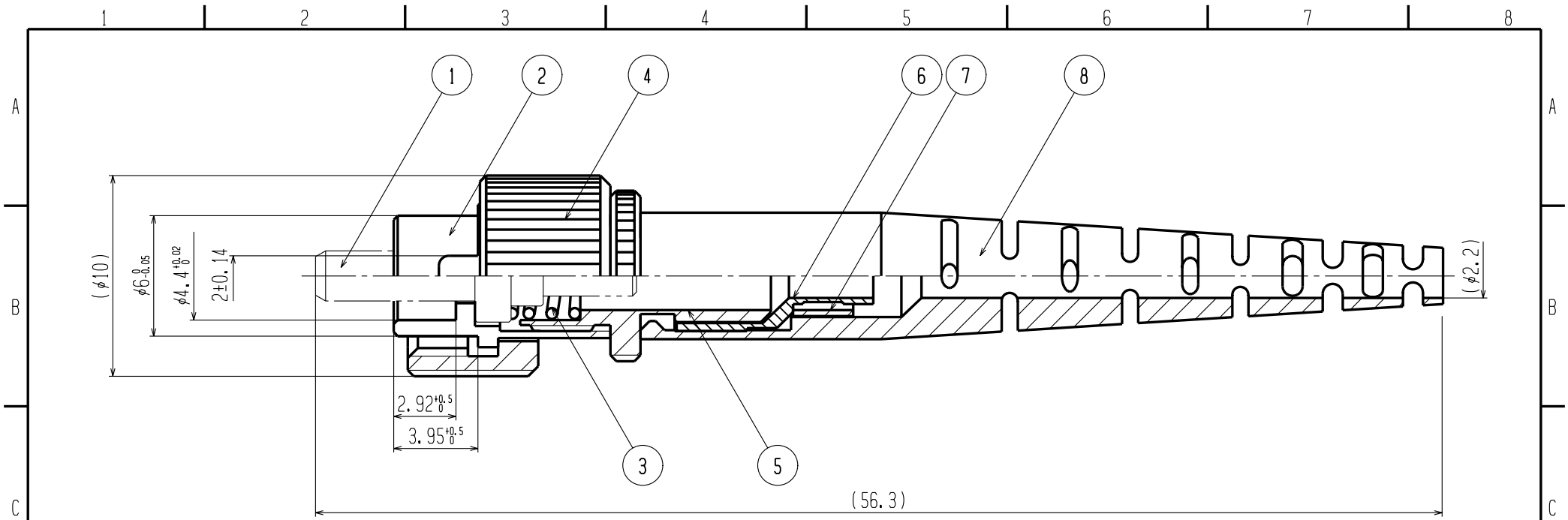

9	1	CAP(BLACK)	PVC	
8	1	FLEXIBLE BOOT(BLUE)	PBT+Si	
7	1	RING	BRASS	Ni PLATING
6	1	CRIMP RING	ALUMINUM	
5	1	HOLDER	BRASS	Ni PLATING
4	1	COUPLING NUT	BRASS	Ni PLATING
3	1	COMPRESSION SPRING	STAINLESS STEEL WIRE	
2	1	FRAME	BRASS	Ni PLATING
1	(1)	FERRULE	-	NOT INCLUDING
NO (番号)	QTY (数量)	TITLE (名称)	MATERIAL (材料)	TREATMENT (処理)

PARTS LIST  
(部品表)

MATERIAL (材料)	PART NO. (型番)	SGP-3 Series	
TREATMENT (処理)	SGP-356011JOG		
SCALE (尺度)	UNIT (単位)	DATE (日付)	TITLE (名称)
Free	1=1mm	2007/09/03	FC HOUSING for PC (360 degree variable tuning)
APPROVED BY (承認)	CHECKED BY (検閲)	DESIGNED BY (設計)	DRAWN BY (製図)
Y. KAKUTANI	D. KUBO	M. JIBIKI	M. JIBIKI
SEIKOH GIKEN Co.,Ltd.			ITEM NO. (品目コード)
			SHEET NO. (枚数)
			PAGE (ページ)
			DRAWING NO. (図番)
			S05-H032-D06E

△		
△		
△		
1	ISSUED	2007/09/03
Rev. (回 数)	DESIGN CHANGE (変更 記事)	DATE (日 付)

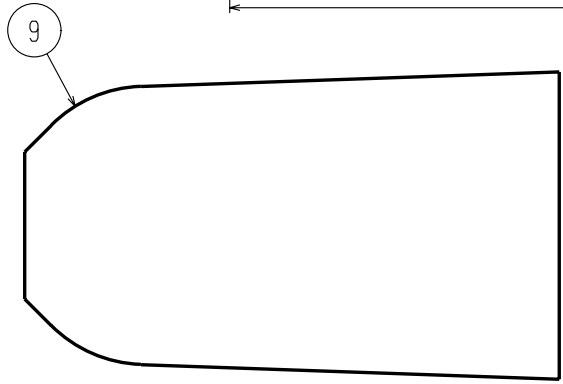
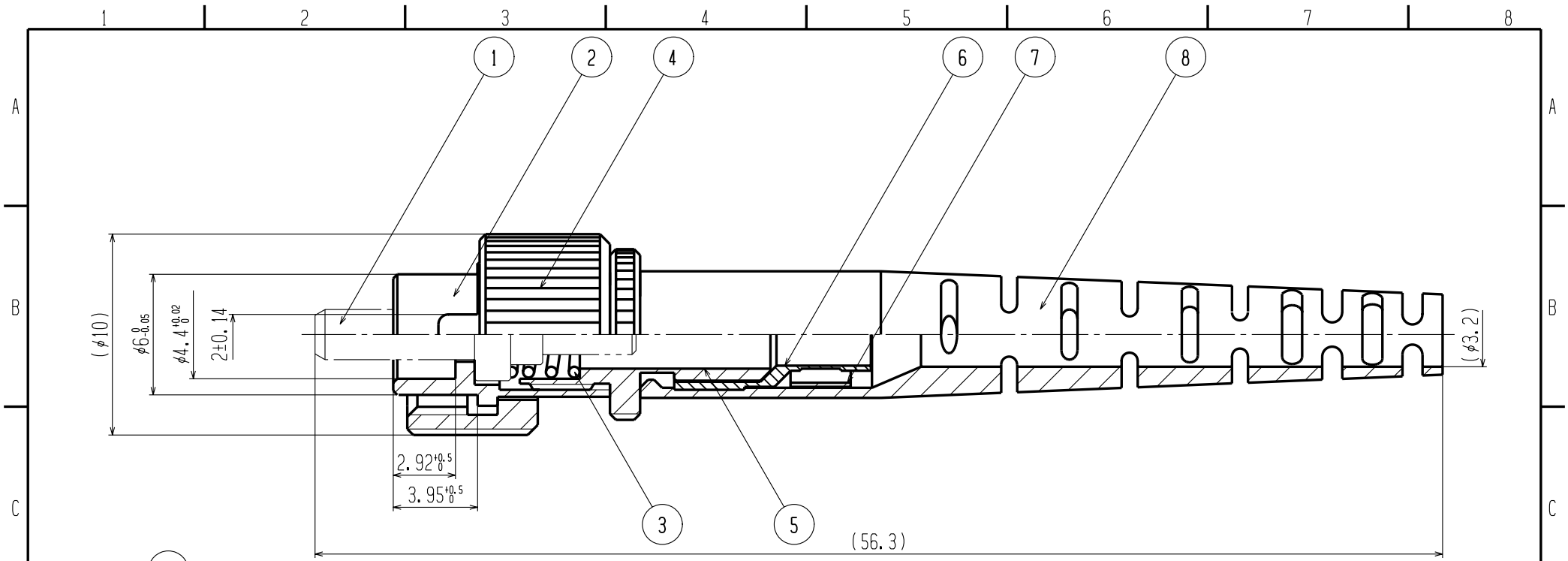

9	1	CAP(BLACK)	PVC	
8	1	FLEXIBLE BOOT(BLUE)	PBT+Si	
7	1	RING	BRASS	Ni PLATING
6	1	CRIMP RING	ALUMINUM	
5	1	HOLDER	BRASS	Ni PLATING
4	1	COUPLING NUT	BRASS	Ni PLATING
3	1	COMPRESSION SPRING	STAINLESS STEEL WIRE	
2	1	FRAME	Zn DIECAST	Ni PLATING
1	(1)	FERRULE	-	NOT INCLUDING
NO (番号)	QTY (数量)	TITLE (名称)	MATERIAL (材料)	TREATMENT (処理)

PARTS LIST (部品表)

MATERIAL (材料)		PART NO. (型番)		SGP-3 Series	
TREATMENT (処理)		DATE (日付)		SGP-357011K0G	
SCALE (尺度)	UNIT (単位)	DATE (日付)		TITLE (名称)	
Free	1=1mm	2007/09/03		FC HOUSING for PC	
APPROVED BY (承認)	CHECKED BY (検閲)	DESIGNED BY (設計)	DRAWN BY (製図)	ITEM NO. (品目コード)	
Y. KAKUTANI	D. KUBO	M. JIBIKI	M. JIBIKI	SHEET NO. (枚数)	
SEIKOH GIKEN Co.,Ltd.				DRAWING NO. (図番)	PAGE (ページ)
				S05-H032-D07E	

△		
△		
△		
1	ISSUED	2007/09/03
Rev. (履歴)	DESIGN CHANGE (設計変更)	DATE (日付)

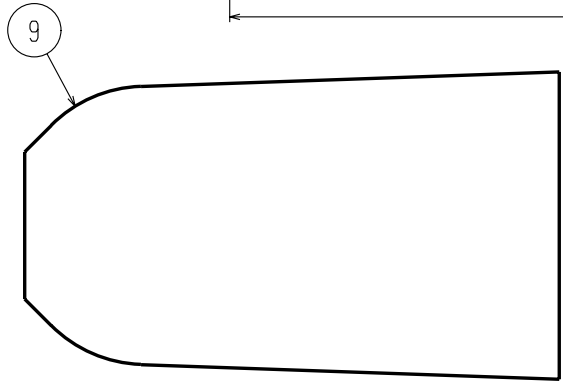
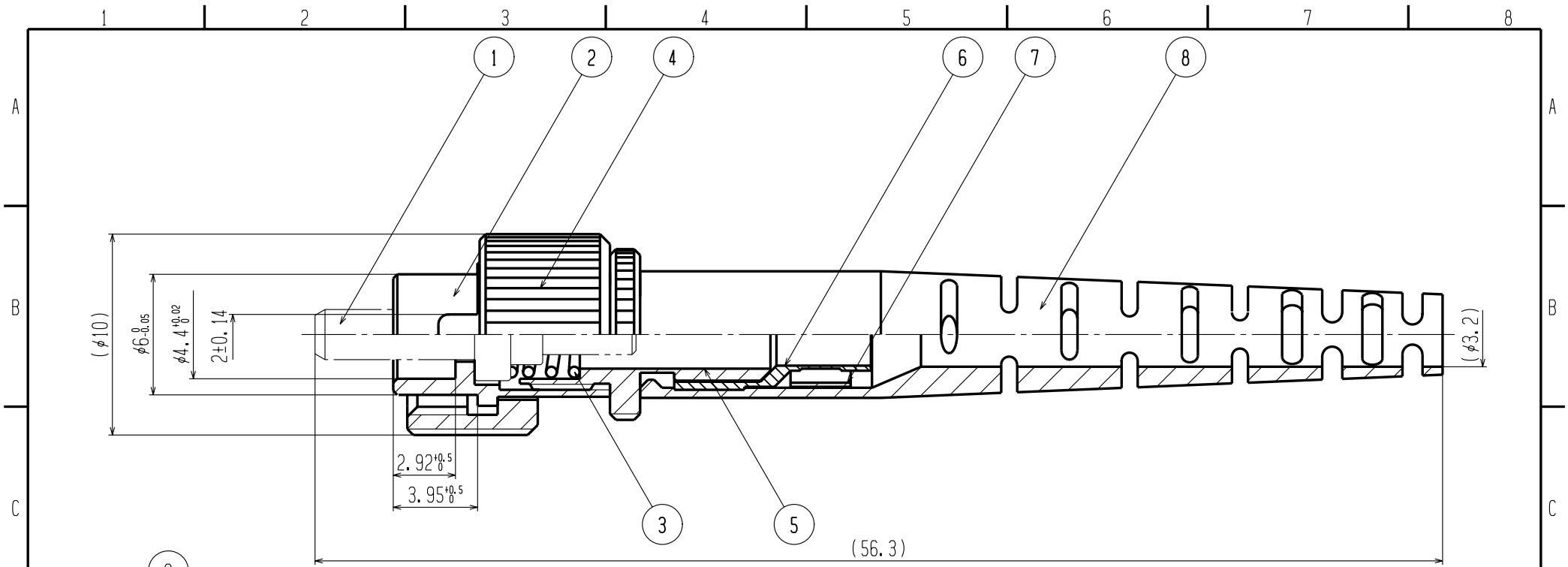

9	1	CAP(BLACK)	PVC	
8	1	FLEXIBLE BOOT(BLUE)	PBT+Si	
7	1	RING	BRASS	Ni PLATING
6	1	CRIMP RING	ALUMINUM	
5	1	HOLDER	BRASS	Ni PLATING
4	1	COUPLING NUT	BRASS	Ni PLATING
3	1	COMPRESSION SPRING	STAINLESS STEEL WIRE	
2	1	FRAME	BRASS	Ni PLATING
1	(1)	FERRULE	-	NOT INCLUDING
NO (番号)	QTY (数量)	TITLE (名称)	MATERIAL (材料)	TREATMENT (処理)

PARTS LIST (部品表)

MATERIAL (材料)		PART NO. (型番)		SGP-3 Series	
TREATMENT (処理)		DATE (日付)		SGP-357011JOG	
SCALE (尺度)	UNIT (単位)	DATE (日付)		TITLE (名称)	
Free	1=1mm	2007/09/03		FC HOUSING for PC	
APPROVED BY (承認)		DESIGNED BY (設計)		ITEM NO. (品目コード)	
Y. KAKUTANI		M. JIBIKI		SHEET NO. (枚数)	
CHECKED BY (検図)		DRAWN BY (製図)		PAGE (ページ)	
D. KUBO		M. JIBIKI		DRAWING NO. (図番)	
SEIKOH GIKEN Co.,Ltd.		DRAWING NO. (図番)		S05-H032-D08E	

△		
△		
△		
1	ISSUED	2007/09/03
Rev. (履歴)	DESIGN CHANGE (設計変更)	DATE (日付)