

SMU-C2 Series

MU HOUSING

- for \varnothing 2 mm cord -

TECHNICAL SPECIFICATIONS



SEIKOH GIKEN Co.,Ltd.
Fiber Optic Products Division
296-1, MATSUHIDAI, MATSUDO-SHI,
CHIBA, 270-2214 JAPAN.
TEL: +81-47-388-6111 FAX: +81-47-388-4477

**SMU-C2 Series MU HOUSING - for \varnothing 2 mm cord -
TECHNICAL SPECIFICATIONS**

| | | |
|--------------|-----------|------|
| ACD-06B4-01 | August | 2000 |
| ACD-06B4-02 | September | 2000 |
| ACD-06B4-03 | February | 2001 |
| S05-H027-01E | July | 2006 |
| S05-H079-01E | January | 2010 |

Copyright © 2000 - 2010 by **SEIKOH GIKEN Co.,Ltd.**
All right reserved.

The information contained herein shall not reproduced or disclosed to any third party without the express written consent of SEIKOH GIKEN Co., Ltd.
The Specifications contained herein are subject to change without notice.

Please address any questions, comments, and suggestions to:

SEIKOH GIKEN USA, Inc.

4405 International Blvd., Suite B109
Norcross, GA 30093 U.S.A.
TEL: +1-770-279-6602 FAX: +1-770-279-8839

SEIKOH GIKEN Europe GmbH

Siemensstrasse 9
D-63263 Neu-Isenburg, Germany
TEL: +49-6102-297-701
FAX: +49-6102-297-750

SEIKOH GIKEN Hong Kong Co.,Ltd.

Concordia Plaza 21/F Rm2111,
1 Science Museum Road, Tsim Sha Tsui East,
Kowloon, Hong Kong.
TEL: +852-26206551 FAX: +852-26206525

TABLE OF CONTENTS

| Section | Page |
|---------------------------|------|
| 1 SCOPE | 1 |
| 2 PART NUMBER | 1 |
| 3 GENERAL SPECIFICATIONS | 2 |
| 3.1 Parts and Materials | 2 |
| 3.2 Physical Dimensions | 2 |
| 3.3 General Tolerance | 2 |
| 3.4 Appearance | 3 |
| 4 PACKING | 3 |
| 5 IDENTIFICATION | 3 |
| 6 HANDLING AND CARE | 3 |
| 6.1 Conditions of Storage | 3 |
| 6.2 Precautions of Use | 3 |
| 6.3 Disposal | 3 |

Table

| | | |
|---------|---------------------|---|
| Table 1 | Part Number | 1 |
| Table 2 | Parts and Materials | 2 |
| Table 3 | General Tolerance | 2 |

Figure

| | | |
|---------------|-----------------------|--------|
| Figure 1 | SMU-C2 Series Housing | 4 |
| Figure 2 to 8 | Dimensions of Parts | 5 to 7 |

1. SCOPE

These specifications apply to the SMU-C2 series MU housing - for ø 2 mm cord - supplied by SEIKOH GIKEN Co., Ltd.

2. PART NUMBER

Part number of the housing is shown in Table 1.

Table 1 Part Number

| MODEL Number | TYPE Number | | | | | | | |
|---------------|-------------|----------------|--------------|-----------------|-------------------|-----------------|----------|-----------------|
| SMU-C2 | 9 | 2 | 0 | C | 3 | 0 | 1 | G |
| Boot Color | | Boot I.D. [mm] | | Marking of Grip | | Auxiliary digit | | Package |
| 5 | Blue | 2 | for ø 2 cord | 0 | SG / SMU-P | 0 | 1 | G |
| 8 | Green | | | | | | | 3 |
| 9 | Lavender | | | | | | | Bulk Package |
| | | | | | | | | Cap |
| | | | | | | | | C |
| | | | | | | | | White Frame Cap |

Please contact us for availability of other specifications.

3 GENERAL SPECIFICATIONS

3.1 Parts and Materials

Parts and the materials are shown in Table 2.

Table 2 Parts and Materials

| No. | Part Name | Qty | Material | Notes |
|-----|---------------|-----|--|---|
| ① | Grip | 1 | PBT GF | Brown Flammability UL94 V-0 |
| ② | Plug frame | 1 | PBT GF | White Flammability UL94 V-0 |
| ③ | Spring | 1 | Stainless Steel | - |
| ④ | Stop Ring | 1 | Brass | Nickel Plating |
| ⑤ | Crimping Ring | 1 | Aluminum Alloy + Heat-shrinkable tubing | Heat-shrinkable tubing: Black, with adhesive liner, Flame-retardant UL224 |
| ⑥ | Boot | 1 | TPEE | Flammability UL94 V-0 |
| ⑦ | Cap | 1 | PP | Frame Cap, White |

Note: Item on Table 2 corresponds to the item reference number on Figure 1 to 8.

3.2 Physical Dimensions

Figure 1 shows the SMU-C2 series housing.

Figure 2 to 8 show the dimensions of the parts.

- In accordance with IEC 61754-6 Type MU connector family.
- In accordance with JIS C 5983 F14 Type connectors.

3.3 General Tolerances

Permissible deviation in dimensions without tolerance indication is in accordance with ISO 2768-m (JIS B 0405-m), as shown in Table 3.

Table 3 General Tolerance (ISO 2768-m)

| Basic size step [mm] | | Permissible deviation [mm] |
|----------------------|-------|----------------------------|
| Over | Under | |
| 0.5 | 3 | ±0.1 |
| 3 | 6 | ±0.1 |
| 6 | 30 | ±0.2 |
| 30 | 120 | ±0.3 |

3.4 Appearance

There should be no burr, peeling of plating or scratches that affect the product.

4 PACKING

The product is packed to prevent damage during shipment.

5 IDENTIFICATION

Identification label should indicate the part number and the lot number of the product(s) and should be permanently attached to the packing bag.

6 HANDLING AND CARE

6.1 Conditions of Storage

For storage of the product, keep in the packing bag and keep away from corrosive gas, high-temperature and humidity, extreme-low temperature and direct sunlight.

6.2 Precautions for Use

Contamination, oil, sweat and others debris on the ferrule end face may influence the performance of the product. If contamination is on the ferrule end face, wipe the end face with the end face cleaner.

6.3 Disposal

When discarding this product, please follow the regulations of your own country.

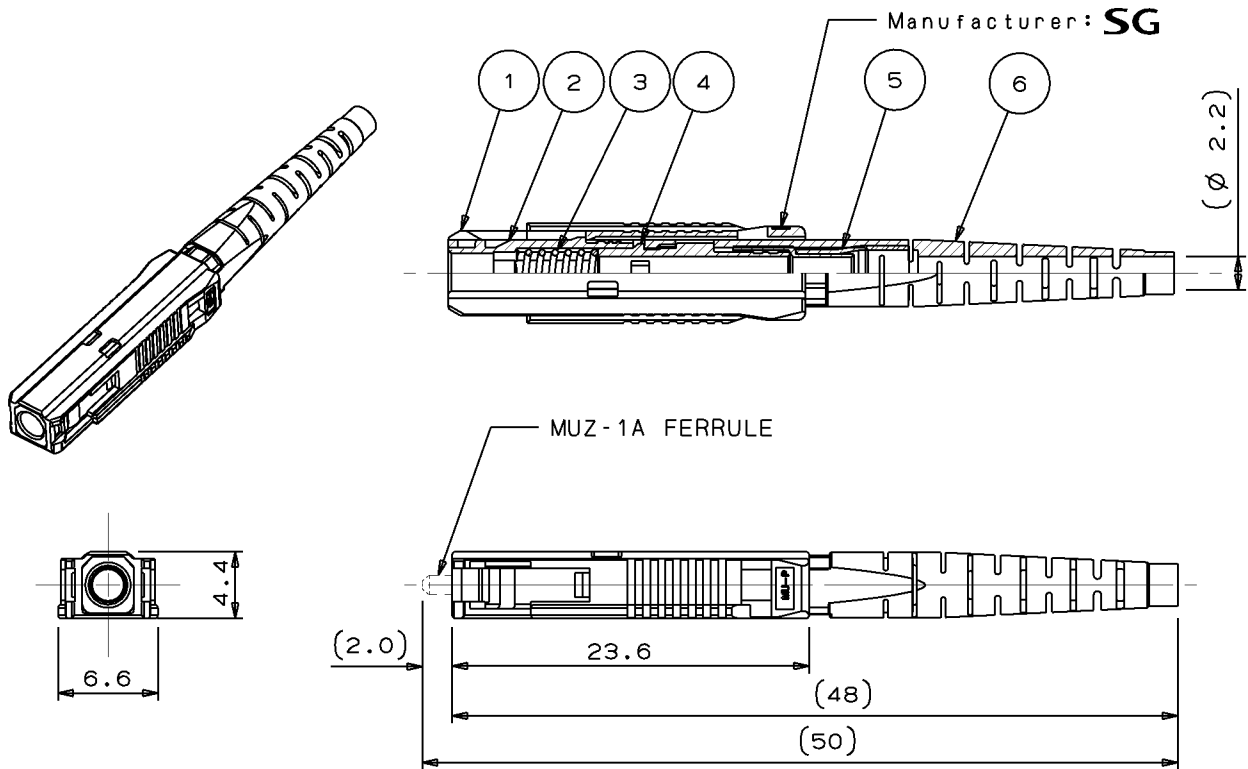

- Notes: 1 This drawing shows the tentatively assembled condition including a ferrule. On practical shipment of SMU-C2 housing, this tentative assembly is not available.
- 2 This drawing does not include the cap.
- 3 The ferrule is not included in SMU-C2 housing.

Unit: mm

Figure 1 SMU-C2 Series Housing

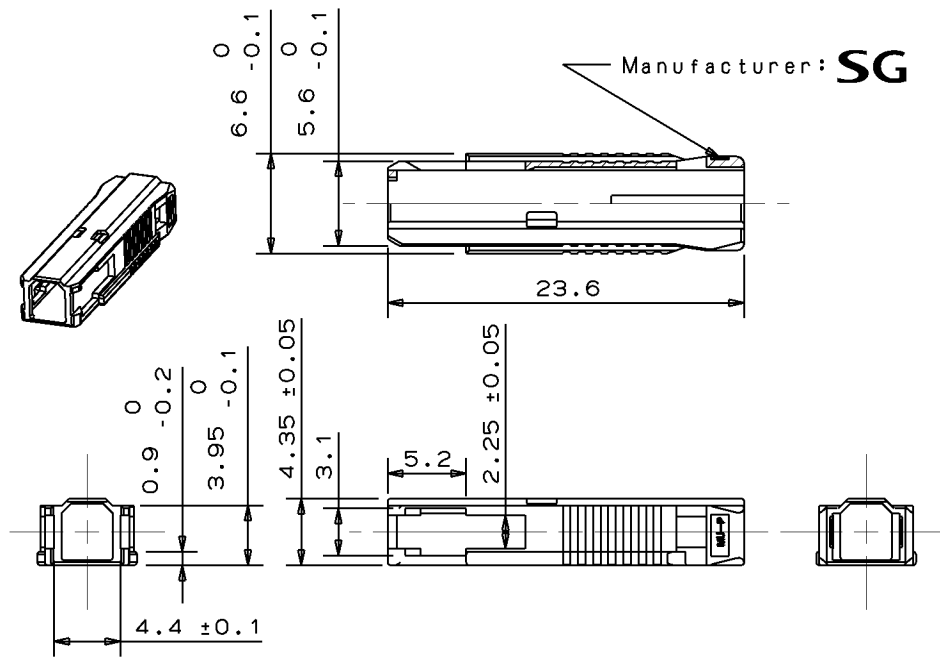

Unit: mm

Figure 2 ① Grip

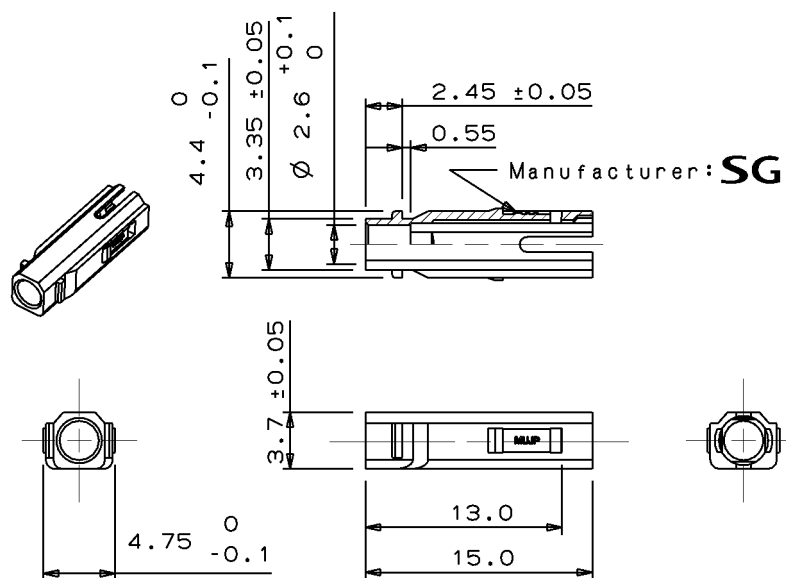

Unit: mm

Figure 3 ② Plug Frame

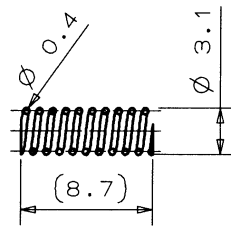

Unit: mm

Figure 4 ③ Spring

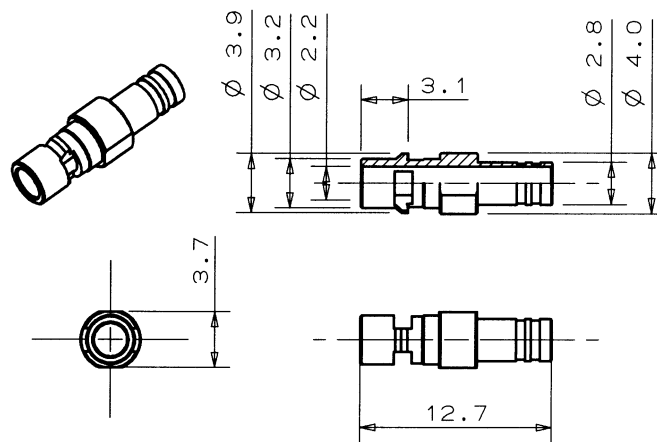

Unit: mm

Figure 5 ④ Stop Ring

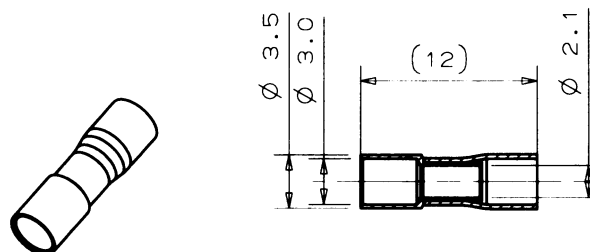

Unit: mm

Figure 6 ⑤ Crimping Ring

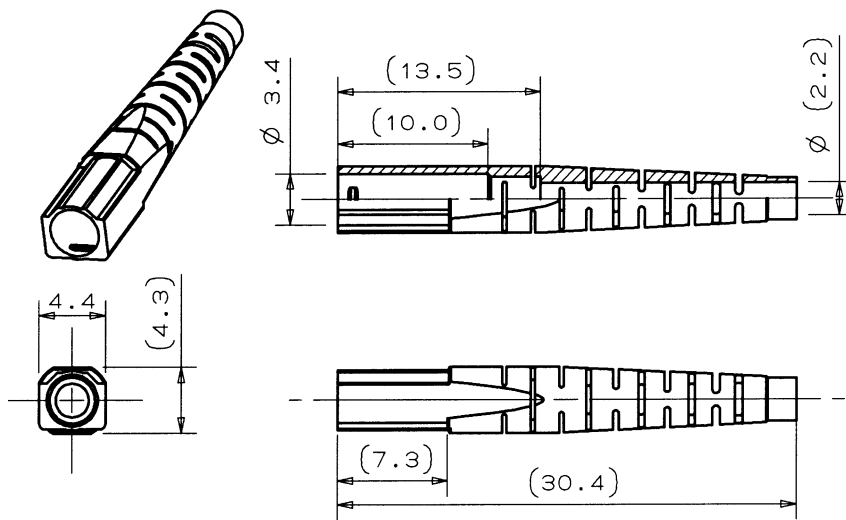

Unit: mm

Figure 7 ⑥ Boot

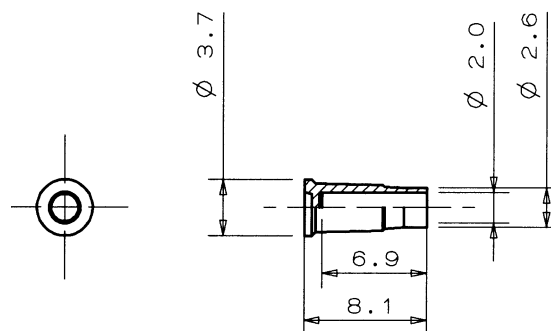

Unit: mm

Figure 8 ⑦ Cap