

SNA-3 Series
FC D-Shape ADAPTOR
- for Angled-PC -

TECHNICAL SPECIFICATIONS



SEIKOH GIKEN Co.,Ltd.
296-1, MATSUHIDAI, MATSUDO-SHI,
CHIBA, 270-2214 JAPAN.
TEL: +81-47-388-6111 FAX: +81-47-388-4477

**SNA-3 Series FC D-Shape ADAPTOR - for Angled-PC -
TECHNICAL SPECIFICATIONS**

NCD-85C4-01	May	1998
NCD-85C4-02	February	2002
S04-H020-01E	July	2006
S04-H020-02E	October	2014
S04-H020-03E	June	2015
S04-H020-04E	March	2021

Copyright © 1998 - 2021 by **SEIKOH GIKEN Co.,Ltd.**
All right reserved.

The information contained herein shall not be reproduced or disclosed to any third party without the express written consent of SEIKOH GIKEN Co., Ltd.
The specifications contained herein are subject to change without notice.

Please address any questions, comments, and suggestions to:

SEIKOH GIKEN USA, Inc.

4405 International Blvd., Suite B109
Norcross, GA 30093 U.S.A.
TEL: +1-770-279-6602
FAX: +1-770-279-8839

SEIKOH GIKEN Europe GmbH

Siemensstrasse 9
D-63263 Neu-Isenburg, Germany
TEL: +49-6102-297-701
FAX: +49-6102-297-750

SEIKOH GIKEN Hangzhou Co.,Ltd.

526 Binkang Road Binjiang District, Hangzhou,
Zhejiang, China 310052, P.R. China
TEL: +86-571-8777-4098
FAX: +86-571-8777-4099

TABLE OF CONTENTS

Section	Page
1 SCOPE	1
2 PART NUMBER	1
3 GENERAL SPECIFICATIONS	2
3.1 Parts and Materials	2
3.2 Physical Dimensions	2
3.3 General Tolerances.....	2
3.4 Insertion Loss.....	3
3.5 Appearance.....	3
4 PACKING	4
5 IDENTIFICATION	4
6 HANDLING AND CARE	4
6.1 Conditions of Storage.....	4
6.2 Precautions for Use.....	4
6.3 Disposal	4

Table

	Page
Table 1 Part Number.....	1
Table 2 Parts and Materials	2
Table 3 General Tolerance (ISO 2768-m).....	2
Table 4 Insertion Loss and Measurement Conditions	3
Figure 1 Insertion Loss Measurement System.....	3

Figure

	Page
Figure 2 SNA-3 Series Adaptor (Wide Key - N-type -)	5
Figure 3 SNA-3 Series Adaptor (Narrow Key - R-type -)	6
Figure 4 to 6 Dimensions of Parts.....	7
Figure 7 Cut-hole Dimensions for Reference	8

BLANK PAGE

1 SCOPE

These specifications apply to the SNA-3 Series FC D-Shape adaptor - for angled-PC - supplied by SEIKOH GIKEN Co., Ltd.

2 PART NUMBER

Part number of the adaptor is shown in Table 1.

Table 1 Part Number

MODEL Number		TYPE Number					
SNA-3		2	2	4	D	0	G

Slit sleeve	
2	Zirconia

Name label	
2	SNA-3  SEIKOH GIKEN

Cap	
4	Green Rubber Cap

Auxiliary digit	
0 G	

Specifications	
D	Wide Key - N-type -
K	Narrow Key - R-type -

Please contact us for availability of other specifications.

3 GENERAL SPECIFICATIONS

3.1 Parts and Materials

Parts and materials are shown in Table 2.

Table 2 Parts and Materials

No.	Part Name	Qty	Material	Notes
①	Adaptor housing	1	Brass	Nickel plating With label
②	Sleeve	1	Brass	Nickel plating
③	Fitting sleeve	1	Brass	Nickel plating
④	Slit sleeve	1	Zirconia ceramics	-
⑤	Washer	1	Steel	Nickel plating
⑥	Nut	1	Brass	Nickel plating
⑦	Cap	2	Silicone	Rubber cap, Green

Note: Item on Table 2 corresponds to the item reference number on Figure 2 to 6.

3.2 Physical Dimensions

Figure 2 and 3 show the SNA-3 series adaptor.

Figure 4 to 6 shows the part dimensions.

- In accordance with IEC 61754-13 Type FC-PC connector family.
- In accordance with JIS C 5970 F01 Type connectors.

Note: Except the width of the key due to no FC Angled-PC specified by IEC.

3.3 General Tolerances

Permissible deviation in dimensions without tolerance indication is in accordance with ISO 2768-m (JIS B 0405-m), as shown in Table 3.

Table 3 General Tolerance (ISO 2768-m)

Basic size step [mm]		Permissible deviation [mm]
Over	Under	
0.5	3	±0.1
3	6	±0.1
6	30	±0.2
30	120	±0.3

3.4 Insertion Loss

Insertion loss of the adaptor and measurement conditions are shown in Table 4. Figure 1 shows the measurement system.

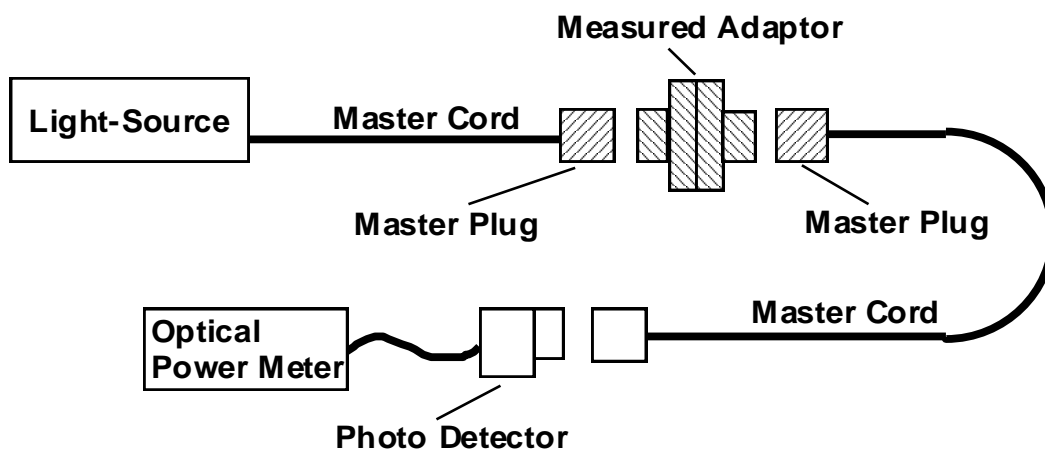

Figure 1 Insertion Loss Measurement System

Table 4 Insertion Loss and Measurement Conditions

Part Number		SNA-3 224*0G
Insertion Loss		0.2 dB or less
Conditions	Light Source	LD
	Wave Length	1.31 μm
	Applicable Fiber	Single mode
	Master Cord Type	Angled-PC

3.5 Appearance

There shall be no burrs or scratches that affect the product.

4 PACKING

The product is packed to prevent damage during shipment.

5 IDENTIFICATION

Identification label should indicate the part number and the lot number of the product(s) and should be permanently attached to the packing bag.

6 HANDLING AND CARE

6.1 Conditions of Storage

For storage of the product, keep in the packing bag and keep away from corrosive gas, high-temperature and humidity, extreme-low temperature and direct sunlight.

6.2 Precautions for Use

Contamination, oil, sweat and others debris on the inside of the slit sleeve may influence the performance of the product. If contamination is on the inside of the slit sleeve, clean the inside before connecting.

6.3 Disposal

When discarding this product, please follow the regulations of your own country.

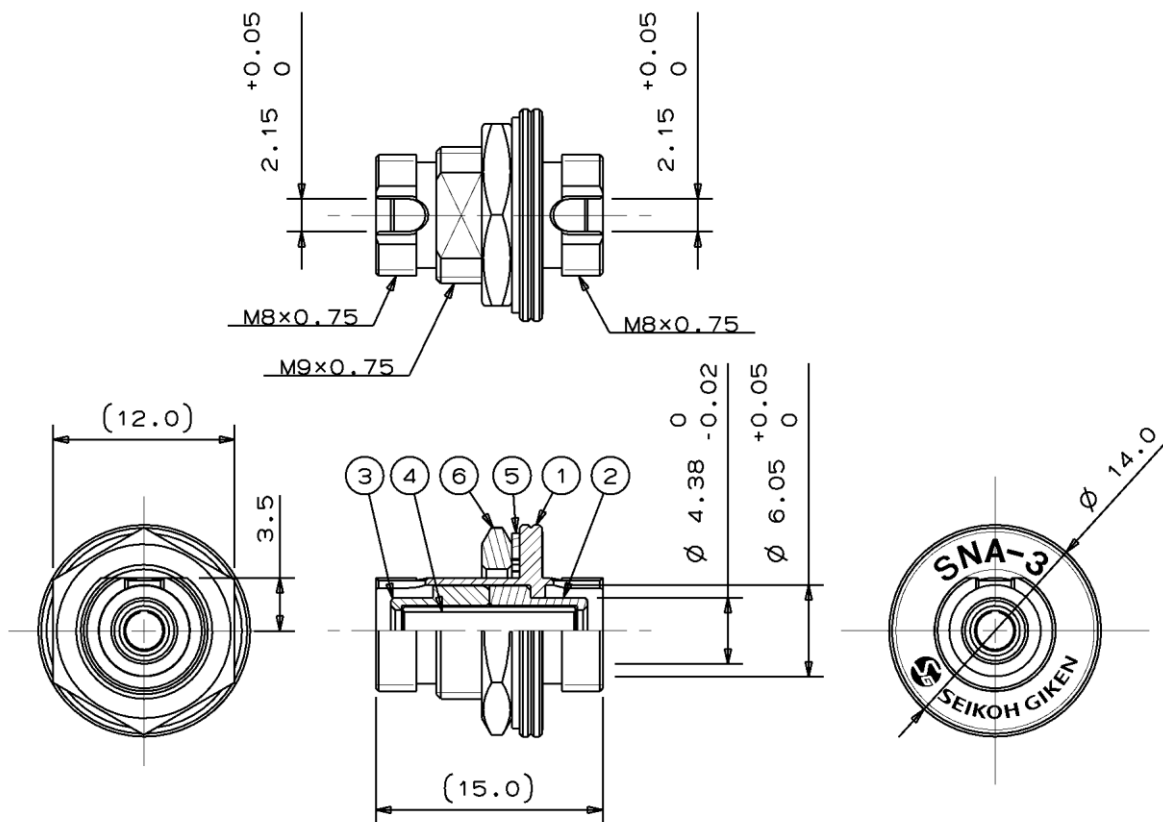

Note: This drawing does not include the cap

Unit: mm

Figure 2 SNA-3 Series Adaptor (Wide Key - N-type -)

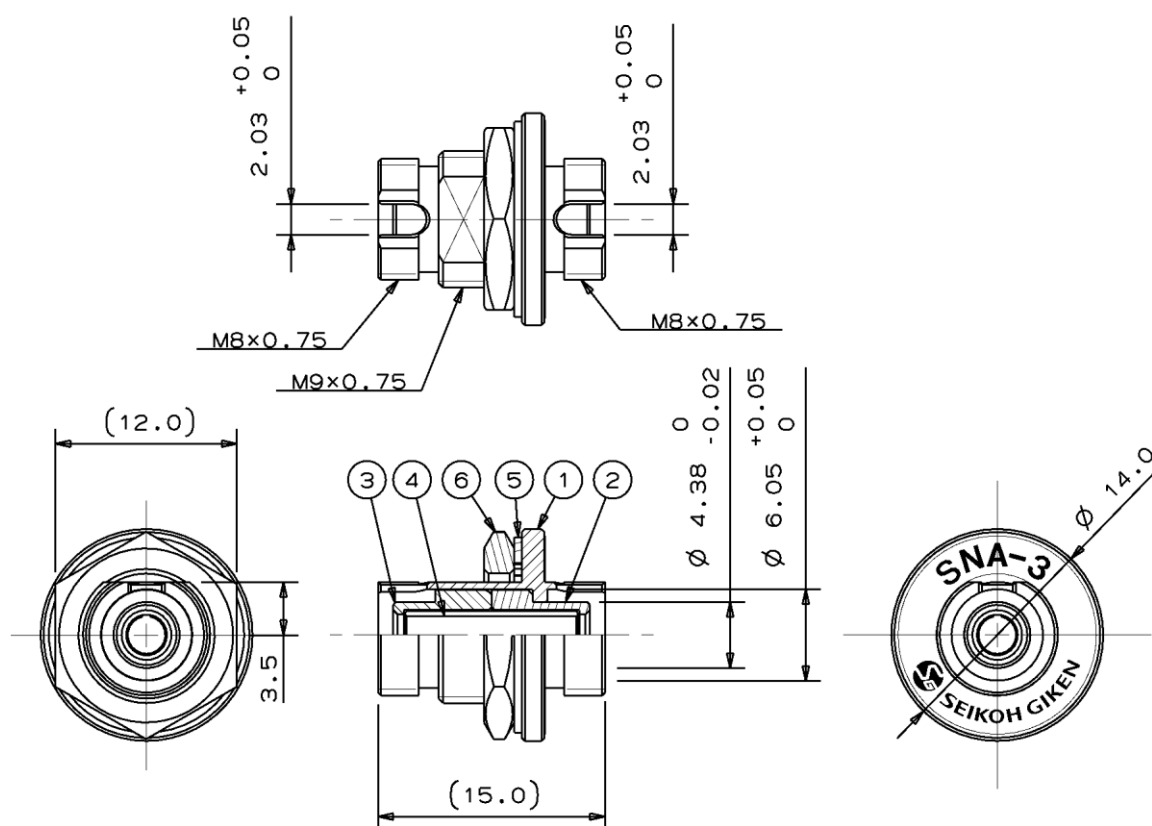

Note : This drawing does not include the cap

Unit: mm

Figure 3 SNA-3 Series Adaptor (Narrow Key - R-type -)

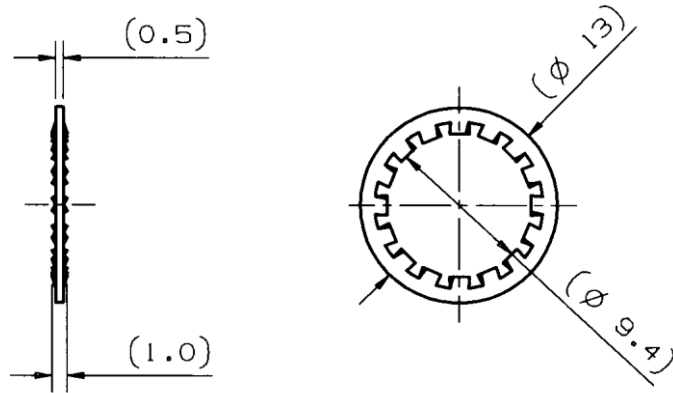

Unit: mm

Figure 4 ⑤Washer

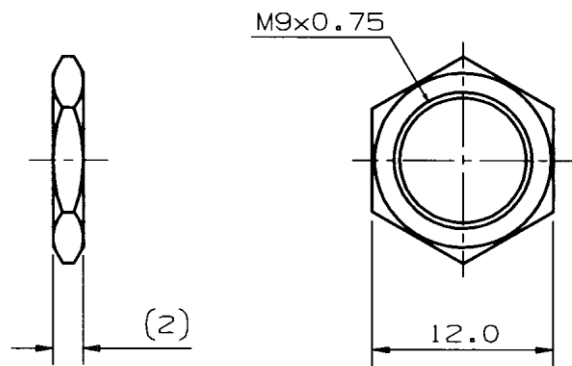

Unit: mm

Figure 5 ⑥Nut

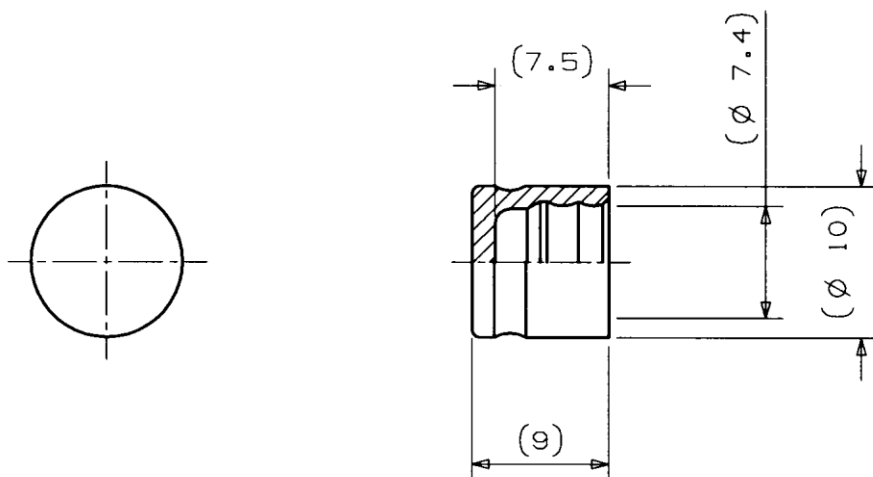

Unit: mm

Figure 6 ⑦Cap

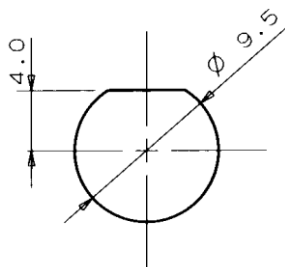

Panel thickness: 1 to 2

Unit: mm

Figure 7 Cut-hole Dimensions for Reference